



GUIDANCE NOTES
GD 02-2012

ISClass

INTERNATIONAL SHIP CLASSIFICATION

GUIDELINES FOR TOWAGE AT SEA

2011

Effective from January 01 2012

CONTENTS

CHAPTER 1 GENERAL PROVISIONS.....	1
Section 1 Purpose and Requirements	1
Section 2 Application	1
Section 3 Application for Survey.....	2
Section 4 Definitions.....	2
Section 5 Conditions for Towing at Sea	4
Section 6 Documentation and Information.	4
Section 7 Survey, Inspection and Certification.	6
Section 8 Management of Towing operation.	7
Section 9 Weather and Sea Wave Forecasts.....	8
CHAPTER 2 TOWED OBJECT – VESSEL.....	9
Section 1 General.....	9
Section 2 Structural Strength of Hull.	9
Section 3 Intact Stability and Damage Stability	10
Section 4 Safety Measures against Entry of Water	11
Section 5 Drainage Facility and Scuppers.	12
Section 6 Anchoring Equipment	12
Section 7 Rudder and Propeller.....	13
Section 8 Lights, Shapes and Sound Signals	13
Section 9 Boarding Facilities.....	14
Section 10 Additional Requirements for Towed Object Normally Attended.....	14
Section 11 Lashing and Securing of Cargo and Equipment.	14
Section 12 Fire-fighting Appliances.	15
Section 13 Towing Points.....	15
Section 14 Measures for Prevention of Pollution	15
Section 15 Miscellaneous.....	15
CHAPTER 3 TOWED OBJECT – MOBILE OFFSHORE DRILLING UNIT AND OTHER OFFSHORE INSTALLATIONS.....	16
Section 1 General.....	16
Section 2 Intact Stability and Speed.....	16
Section 3 Free Surface of Liquid Tanks and Closure of Openings	18
Section 4 Lashing and Securing.....	18
CHAPTER 4 TOWING VESSELS.	19
Section 1 General.....	19
Section 2 Communication Equipment.	20
Section 3 Equipment for Transfer of Personnel	20
Section 4 Miscellaneous	20
CHAPTER 5 TOWING EQUIPMENT AND GEARS	22

Section 1 General.....	22
Section 2 Towing Winch	22
Section 3 Towing Equipment and Gears.....	23
Appendix 1 Strength Standard of Supporting Members and Lashing Components.....	28
Appendix 2 Estimation of Ocean Towage Resistance	34
Appendix 3 Bollard Pull Testing Procedure	36
Appendix 4 Towing Log.....	38
Appendix 5 Multiple Towages.....	39

CHAPTER 1 GENERAL PROVISIONS

Section 1 Purpose and Requirements

1.1.1 The Guidelines are provided by International Ship Classification (ISC) for the guidance notes of technical services for ocean towing survey.

1.1.2 If the applicant applies or the Administration authorizes ISC for towing survey, ISC is to carry out the survey according to the Guidelines, unless otherwise specified by the flag State Administration for the towed objects or towing vessels.

1.1.3 During the ocean towing, the class requirements for towed objects are to be in compliance with the relevant provisions of Section 9, Chapter 2 of PART ONE in ISC Rules for Classification of Sea-going Steel Ships.

1.1.4 In the case that surveyor has doubt about the routine work of towing fitness or finds it is beyond the experience or normal procedural requirements, the towed object or towage management personnel is to be required to provide an assessment report of towing fitness for the towed object issued by the recognized plan approval organization.

1.1.5 Where the towing survey involves the cargoes carried on the deck of towed object or the lashing arrangement of equipment, the information of such lashing arrangement at sea, lashing strength calculation and provision of equipment is to be submitted for examination.

1.1.6 The Certificate of Fitness for Towage is to be issued together with the survey report. Where there is no strength and stability information, the applicant is to supplement and submit the assessment of towage fitness for examination.

Section 2 Application

1.2.1 The Guidelines applies to towage operation at sea, which are not in the nature of salvage, involving the towed objects with the following types:

- (1) ships not propelled by mechanical means (including barges and pontoons) and floating structures;
- (2) floating docks, floating installations and other surface structures;
- (3) mobile offshore drilling units and other offshore installations;
- (4) motor vessels losing of propelling capability, but excluding towed vessels under salvage and emergency cases.

The Guidelines does not apply to shifting of engineering vessels, such as crane ship, dredger, etc. within operation areas and the towage of vessels within harbors.

Section 3 Application for Survey

1.3.1 Towing survey may be applied to ISC by the owner of the towing vessel or leaseholder of the towed object, or related underwriter or ship agency.

1.3.2 The applicant is to submit the documentation and information stipulated in the Guidelines and provide convenience and condition for the survey work.

1.3.3 The applicant is to pay survey fee, transportation fee and other necessary expenses according to the provisions of ISC.

Section 4 Definitions

1.4.1 “*Towed object*” generally means the ships not propelled by mechanical means such as barges, crane ships, pile driving boats, dredgers, salvage boats, pipe-laying ships, pontoons and offshore installations such as floating installations, surface structures, mobile offshore drilling units and other offshore installations, as well as motor ships losing of the propelling capability as the mechanical means of propelling is damaged, excluding the towed vessels under emergency and salvage cases.

1.4.2 “*Towing equipment*” means the equipment on the towing vessel and towed object for towage operation, which covers towing winch, hook, towing arch, towline drum, chock (fairlead) , line bracket, D-ring, towing pin, shark jaw onboard the towing vessel, as well as the towing point (towing eye plate or towing bollard), chock (fairlead), etc. fitted on the towed object.

1.4.3 “*Towing gears*” means those gears on the towing vessel and towed object specially used for towage operation, including main towline and spare towline, wire rope bridle/chain bridle, short pennant, delta eye plate, towing ring, shackle, emergency towline, etc.

1.4.4 “*Bollard pull (BP)*” means the continuous bollard pull documented on the bollard pull testing certificate.

In general, the bollard pull is the towing force provided under the rated of the main propelling unit of the towing vessel when the vessel’ s speed in calm water (Beaufort wind scale less than 3, i.e. wind velocity does not exceed 5m/s, current velocity does not exceed 0.5 m/s) is equal to zero.

1.4.5 “*Breaking load (BL)*” means the minimum breaking load of towing gears documented on the certificate.

1.4.6 “*Main towline*” means the connecting line between the towing vessel and the towed object.

1.4.7 “*Spare towline or emergency towline*” means the line used to be instead of the main towline when it is in failure or to maintain the towed object stable temporarily.

1.4.8 “*Wire rope bridle/chain bridle*” means the connection line used for larger towed object, connecting the lead line or chafing chain of towing points arranged on both sides of the towed object (towing eye plate or towing bollard) and the delta eye plate to maintain the steady course of the towed object.

1.4.9 “*Wire rope bridle/chain bridle Apex*” means the connecting unit between the bridle apex and the origin of short pennant, such as delta eye plate, towing ring or shackle. Where the towing fitting with single wire rope bridle/chain bridle is used, the wire rope bridle/chain bridle is usually to be connected to the short pennant by towing ring or shackle.

1.4.10 “*Short pennant*” means the cable connecting delta eye plate or wire rope bridle/chain bridle and towline of the towing vessel.

1.4.11 “*Towing point*” means the fittings specially for connecting the towline or wire rope bridle/chain bridle on the towed object, including the towing eye plate or towing bollard.

1.4.12 “*Towage*” means the whole process of towage operation, including the towing vessel accepting the towage work for the towed object at the departure port, towing to the destination port and delivering the towed object.

1.4.13 “*Commercial towage*” means the towage operations, which are not in nature of salvage and are non-emergency towing.

1.4.14 “*Ocean towing*” means the commercial towage operations between designated ports of refuge or safe anchoring along the route, taken into account weather conditions.

1.4.15 “*Environmental conditions*” mean the load caused by weather and sea conditions, such as wind, wave, ice, snow, etc. Under the normative weather and sea conditions, the bollard pull required by the towed object is to maintain the steady course of the towage, it is to be counterpoised by the following weather and sea conditions, acting in the same direction:

- wind: 20 m/s
- significant wave height: 5 m
- current: 0.5 m/s

Other criteria may be acceptable if high confidence on the weather forecasts and experience data for the actual waters can be obtained.

1.4.16 “*Benign area*” means an area that is free from tropical revolving storms and traveling depressions, but excluding the areas such as the North Indian Ocean during the Southwest monsoon season, and the South China Sea during the Northeast monsoon season. The weather conditions of Benign area are as follows:

- wind: 15 m/s
- significant wave height: 2 m.

1.4.17 “*Tug master*” means the master of a towing vessel.

1.4.18 “*Towing master*” means the manager responsible for the towage. A tug master may be designated as a towing master.

1.4.19 “*Towing length*” means the horizontal distance measured from the stern of towing vessel to the aft end of the last towed object.

Section 5 Conditions for Towage at Sea

1.5.1 A towing plan and a towage operation manual (if any) are to be prepared and the copies are to be kept by the owner and onboard the towing vessel.

1.5.2 The Certificate of Fitness for Towage and Survey Report of Towage at Sea issued by ISC are to be available.

1.5.3 The crew of towing vessels are to have qualification certificates for towage at sea.

1.5.4 The ocean towage is to be carried out under the predetermined sea and weather conditions, the designed environmental conditions of towing vessel is to be superior to those conditions and the certified towing strength and stability of the towed object can not be inferior to those conditions.

1.5.5 The ocean towage is to be carried out according to the approved route in the towing plan and towage operation manual.

1.5.6 The towing vessel is to hold the safety certificate applicable to the whole area of towing route.

Section 6 Documentation and Information

1.6.1 The towing plan and towage operation manual are to be available, the plan is generally to include the following:

- (1) the main dimensions of towing vessel and towed object and the bollard pull of the towing vessel;
- (2) according to the factors such as anticipated weather condition, tide and current, the size, configuration, windage area and displacement of the towed object and any navigational hazards to be avoided, etc., the pre-planned route, including towage sea area, route, distance, speed and the estimated departure and arrival dates;
- (3) arrangement of towing equipment and gears and emergency plan to response to the bad weather, especially the arrangement of hove-to condition and shelter. Where the towed object is normally attended, both towing vessel and towed object are to be provided with towing plan and emergency plan;
- (4) the available ports of refuge or anchorage on the predetermined towing route, refueling program for the towing vessels, expected environmental conditions and towing plan including the ports of departure, arrival and call en route;
- (5) arrangement of towage operation, which is to include towing formation, recovering facilities (for the barge normally attended during the towage) and the connection of main towline and emergency towline. Where more than one towing vessels are to be involved during the towage, the position of each towing vessel and the name of main towing vessel are to be addressed.

1.6.2 The towed object is to hold the related certificate or report applicable to the towing route. An appropriate assessment document or report may substitute the certificate or report for the towed object which is long-period laid-up, scrapped, measures are taken to strengthen temporarily during the towage or interim repair is carried out due to sea damage or the others, such as caisson, cutter-suction dredger, similar structure, etc.

1.6.3 Information of the towing vessel and towing equipment

(1) The towing vessel is to include the following information:

- ① statutory certificate;
- ② class certificate (if any);
- ③ bollard pull testing certificate or related document.

(2) The towing equipment and gears are to include the following information:

- ① type and rated pull of towing winch;
- ② specification, length and breaking strength of main towline and emergency towline;
- ③ drawings or information of towing gears and connection equipment, if applicable, including the short pennant, wire rope bridle/chain bridle, delta eye plate and hook.

1.6.4 Information of the towed object – vessel

(1) The information of towed object is to include the type, name, distinctive number or call sign of the vessel, port of registry, towing draught, information of intact stability and damage stability under towing condition (barge normally attended), as well as specification of anchoring and mooring equipment.

For the long-period laid-up and scrapped towed object, the above-mentioned information may be decreased properly, at least information of the type, main dimension, towing draught, towage stability report, assessment report of towing strength for the towed object is available.

(2) The information of towing equipment and gears are to include the arrangement of towing bollard or towing eye plate and fairlead, arrangement and strength of emergency towline, towing ring, shackle, if applicable, also include the short pennant, wire rope bridle/chain bridle and delta eye plate.

(3) The number of riding crew onboard the towed object during the towage.

1.6.5 Information of the towed object – mobile offshore drilling unit and other offshore installations

(1) Towing plans, towage operation manual, towage stability calculations, calculation of bollard pull needed by towage.

(2) The information of towing equipment and gears are to include the arrangement of towing bollard or towing eye plate and fairlead, arrangement and strength of emergency towline, towing ring, shackle, if applicable, also include the short pennant, wire rope bridle/chain bridle and delta eye plate.

(3) The number of riding crew onboard the towed object during the towage.

1.6.6 Information of the towed object with other special structure

(1) Assessment report of towing strength and towage stability issued by the recognized organization.

1.6.7 Where the cargoes are carried on the deck of towed object:

(1) information of supporting structures and fastenings or lashing equipment of the carried object;

(2) the corresponding strength calculations together with the other related drawings;

(3) welding procedure specification and welding quality report of weather deck fastenings.

Section 7 Survey, Inspection and Certification

1.7.1 The following inspections and tests are to be carried out for the towed object:

(1) to confirm the validity of certificates and relevant documents of towed object;

(2) to confirm the structural strength and towage stability of towed object are applicable for the intended towage route;

(3) temporary repair or strengthening project for towage is to be inspected and tested;

(4) loading and securing arrangement is to be inspected for the tow object intended to load, and it is to be in compliance with the requirements of loading and securing strength calculations. Lashing and securing are to be reliable;

(5) safety measures against flooding, drainage facility and scuppers, anchoring and mooring equipment, fixity of rudder and propeller, navigation lights and shapes, embarkation arrangements, as well as the towing equipment including towing point (towing eye plate or towing bollard, etc.) and fairlead are to be inspected and tested;

(6) to confirm the temporary strengthening facilities of towing bollard and towing eye plate in compliance with the relevant provisions of design and construction quality;

(7) if the surveyor has any doubt about the structure below the waterline of towed object, the towed object company or towage company is to be required to provide an assessment report of the fitness for towage of the under-water structure issued by a professional organization or an inspection is to be required to carry out under water or in dock;

(8) if the surveyor has any doubt about the fitness of towage and steady course for the towed object with special linear, a trial towage may be required to verify and the towing plan is to be adjusted according to the result of the trial;

(9) the towed object normally attended during towage is to be inspected and confirmed according to the requirements of Section 10 of Chapter 2;

(10) to confirm the spare towline or emergency towline is to be provided, arranged and connected in normal order;

(11) to inspect the technical conditions of towing equipment and gears and in compliance with the relevant provisions. If necessary, the chafing chain structure for connecting the wire rope bridle is to be inspected.

1.7.2 The following inspections and tests are to be carried out for the towing vessel:

(1) to confirm the fitness and validity of certificate of towing vessel;

(2) to confirm the relevant technical document and information and towing plan are applicable for the intended towage;

(3) to confirm the towing gears provided onboard the towing vessel hold the certificates and are applicable for the intended towage operation;

(4) the maneuvering system and braking system of towing winch are to be inspected and tested;

(5) towline, fairlead, etc, if applicable, including wire rope bridle, shackle, delta eye plate and short pennant are to be inspected and tested;

(6) damage protection is to be inspected for abrasive parts of towline;

(7) to inspect the towing hook unit and emergency releasing system if a towing hook is used during the operation.

1.7.3 Upon satisfactory survey on the towing vessel and towed object, the Certificate of Fitness for Towage and the relevant survey report are to be issued.

1.7.4 The period of validity of the Certificate of Fitness for Towage is generally from the departure port (place) to the final destination port (place) of the towage, and it is to be marked on the certificate.

1.7.5 Any change or modification of the towing plan or operational condition is to be reported to the organization issuing the certificate for re-approval.

Section 8 Management of Towage operation

1.8.1 During the whole period of towage, the towing master or tug master is to take measures to ensure to meet each requirement of towing plan.

1.8.2 If special circumstance occurs during the towage, and the provisions of original towing plan can no longer be followed, the towing master or tug master is to take the measures to change the plan corresponding to special circumstance based upon his navigational experiences. Any change of the plan is to be reported to the towage company and ISC immediately.

1.8.3 When the towing master or tug master selects the course and route near the seashore or shallow waters, the towing vessel is to enter the safe waters at an appropriate speed or keep away from seashore or shallow waters under the predetermined tidal current and weather condition as far as possible.

1.8.4 For the towed object normally unattended during the towage, the towing master or tug master is to send someone boarding the towed object to carry out inspection and make the records correspondingly.

1.8.5 The towing master or tug master is responsible for the implementation of towage operation as well as route and speed change under the bad weather condition, including shelter, bunkering or replenishment, etc. In order to ensure the safety of the fleet during the towage, the towing master has the rights to take rational and necessary emergency measures. The primary responsibility of a towing master is to assure the safety for personnel and equipment (including the towed object).

1.8.6 Where the towed object presents a direct damage to navigation, offshore structure or coastline through breaking adrift or for some other cause, the towing master or tug master is to take measures to keep away from the damage and communicate the information by all the means at his disposal to ships in the vicinity, and also to the Administration at the first point on the coast with which he can communicate.

Section 9 Weather and Sea Wave Forecasts

1.9.1 A weather forecasting facility at least for the future 24 h is to be provided onboard the towing vessel during the whole towage operation.

1.9.2 Weather and sea wave forecasts for the future 24 h in towing commencement area are to be received prior to the anticipated departure time of the towing vessel.

1.9.3 Weather and sea wave forecast is at least to include following information:

- (1) synopsis of the area;
- (2) wind velocity and direction;
- (3) wave height and period;
- (4) swell height and period;
- (5) outlook for the future 48 h. If the period of towage operation exceeds 72 h, the outlook for the future 72 h is to be provided.

1.9.4 The towing vessel is to receive the weather and sea wave forecast at least from two different forecasting stations to confirm that a sound weather and sea condition is kept during a period after the departure.

1.9.5 For the towed object normally attended during the towage, the riding crew is to contact with the towing vessel during the whole towage to obtain the weather and sea condition forecast. The riding crew onboard the towed object is to receive the weather and sea condition forecasts at least every 12 h and compare with those obtained from the towing vessel.

1.9.6 During the towage, if there are specific weather and sea condition, more frequent forecasts are to be received by the towing vessel. Where significant changes occur, it is to communicate directly with the forecaster to study the outlook for the weather and sea condition and report to the towage company for discussion. The towage company is to report the discussed measures to ISC.

CHAPTER 2 TOWED OBJECT — VESSEL

Section 1 General

2.1.1 The towed objects are the ships not propelled by mechanical means or other similar structures which are designed according to the current ISC Rules for Classification of Sea-going Steel Ships or other recognized standards, such as barge and large square-shaped pontoon, and the structures have been properly maintained, it is regarded that the technical status such as structural strength and towage stability are fit for being towed under normative weather and sea conditions.

2.1.2 The towed objects are the ships other than those not propelled by mechanical means or other similar structures which are designed according to the current ISC Rules for Classification of Sea-going Steel Ships or other recognized standards, such as floating dock, pontoon, river boat or the others, it is to strengthen, lash and secure the structure and towing equipment properly and raise the limitations for towage according to the specific conditions, i.e. characteristic of towed object, route, weather and sea conditions, etc.

2.1.3 Where it is regarded that there is a special structure with adverse effect to the structural strength and towage stability onboard the towed object during the towage, such as crane jib, piling driver, pipe-laying facility, etc., the special structure is to be lowered or retrieved and secured. If documentation is provided by the competent authority, it may not be lowered compulsorily.

2.1.4 Inspection must be carried out by the surveyor prior to the towage operation in order to ensure the safety if the towed object is a motor vessel which loses power caused by sea damage or engine damage.

Section 2 Structural Strength of Hull

2.2.1 Where the structural strength of hull of towed vessel is in compliance with the current ISC Rules for Classification of Sea-going Steel Ships or other recognized standards and the towage operation is carried out under the normative weather and sea conditions, it is considered that the structural strength is satisfied.

Where the towed object is a motor vessel losing of power caused by sea damage or engine damage, the damaged part is to be repaired permanently or temporarily to restore its required strength and watertightness, it is considered that the strength and watertightness are satisfied.

2.2.2 Where the towed object is not a ship which is designed according to the current ISC Rules for Classification of Sea-going Steel Ships or other recognized standards, strengthening measures are to be taken under the normative weather and sea conditions or the ocean towing is to be restricted to carry out within the benign season and area.

For floating dock, total twisting stress is to be examined with special attention.

2.2.3 If heavy equipment, structural members or cargoes are carried on the towed vessel during the towage, the towage company or manager of towed objects is to provide the check report of supporting structures and the securing equipment so as to ascertain that they have adequate towing strength.

The load calculation acting on supporting members and lashing components of towed objects and their strength standard are given in Appendix 1.

The dimension of barges for carrying jackets or other large-sized installations are to be suitable for those of the jackets or other large-sized installations. The deck structure of barge is to be strengthened properly as to have sufficient strength.

2.2.4 The towing point, including the towing eye plate, towing bollard and fairleader is to be designed according to the standards of towing equipment required by flag State Administration or the recognized organization so that it is capable of withstanding 1.3 times the minimum breaking load for the main towline determined by the bollard pull and without permanent deformation. Appropriate strengthening is to be required for the corresponding parts of the hull structure.

2.2.5 Where double wire rope bridles are used, the towing eye plates are to be arranged symmetrically at both sides.

Section 3 Intact Stability and Damage Stability

2.3.1 The intact stability of the towed object during the towage is to comply with the relevant requirements of the flag State Administration. In order to avoid the effect upon intact stability of the free surface for the towed object, it is recommended that all of its tanks are to be maintained in loaded or ballast condition during the towage.

2.3.2 In order to avoid the effect on intact stability and damage stability of the towed object by carrying jackets or other large-sized installations, the stowage and arrangement of the jackets or large-sized installations are to be taken into account.

2.3.3 The damage stability of towed object normally attended by more than 12 persons during the towage is to be checked according to the provisions of the flag State Administration.

2.3.4 The towed object is to be with an appropriate draught and recommended to be trimmed by the stern during the towage so as to maintain the stable course of the fleet and reduce the effect of slamming to the towed object. Loading, draught and trim of towed object are to be in compliance with the towing plan and towage stability.

2.3.5 The towed object is to be with an appropriate draught and trim, proper trim by the stern is recommended along the towing direction and it is to be at least in a horizontal state, however, trim by the bow can not be acceptable. The fore and aft draughts of towed object – vessel at sea are recommended in Table 2.3.5. Generally, there is to be no or less trim by the stern for box-shaped towed object.

Fore draught and difference between the fore and aft draughts Table 2.3.5

Length of the towed vessel (m)	Fore draught (m)	Difference between fore & aft draughts (m)
30	0.90	0.30
60	1.80	0.60
90	2.40	0.80
120	3.00	1.00
150	3.50	1.10
180	4.00	1.30
210	4.80	1.50

Note: Based on the practical experience, the ratio between the difference of fore & aft draughts and the length of towed vessel will be reduced by the increase of the length. According to the operational experience, the difference of fore & aft draughts is generally about 0.75% the length if the towed vessel exceeds 150 m. It is showed that the excess difference is not advisable.

2.3.6 The trim by the stern of towed object is determined by the towing master or tug master.

2.3.7 The trim by the stern of barges carrying with jackets or other large-sized installations is to be coordinated with the requirements of loading and offshore installation procedure.

Section 4 Safety Measures Against Entry of Water

2.4.1 For the towed object carrying the deck cargo, it is to ensure the availability of the drainage facilities on the freeboard deck and the loading of deck cargo will not affect the original freeboard assignment or the provisions of the flag State Administration.

2.4.2 Jamming of the shutters of freeing ports of the bulwarks on weather freeboard deck is to be prevented. Scuppers and discharges are not to be blocked by the loaded deck cargo or fixed installations on deck.

2.4.3 Closing appliances of various openings on weather freeboard deck and superstructure deck are to be availability.

2.4.4 Requirements for closing appliances

(1) Towed object – vessel:

- ① Hatchways, ventilators, air pipes, doors, windows and other openings through which sea water may flood into the vessel and affect its stability are to be closed weathertightly. Side scuttles are to be closed with deadlights and fixed firmly. Any watertight doors or other closing appliances in the hull are to be in close state.
- ② Sea valves and overboard discharge valves not in use during the towage are to be closed and locked. The closing devices of sanitary discharge are to be locked in the closing position as far as practicable.

(2) Other towed object:

- ① Practicable measures are to be taken to satisfy the requirement of (1) above.
- ② For the towed object normally unattended, the side scuttles of each cabin below the freeboard deck and the first tier of superstructure or deckhouse above the freeboard deck are to be closed with deadlights and locked if the deadlights are provided; otherwise, steel plating or other effective means are to be taken to protect suitably on the external side.
- ③ For the towed object normally attended, various openings through which sea water may flood into it are to be closed weathertightly except those used by the crew.

2.4.5 Means for leakage detection and leak stopper

(1) All bilges and wells in cargo holds, double-bottom tanks, void spaces, cofferdams, oil tanks and water tanks are to be fitted with sounding facilities. It is to ensure the watertightness of sounding pipe covers for various oil tanks and water tanks on weather deck.

(2) The towed vessels are to be equipped with adequate amounts of leak stopper.

2.4.6 For the towed object normally unattended, a mark line with the width of 0.5 m and length not less than 1 m is to be painted at a proper position above the fore draught mark and in a color easily discriminated from the shell plate when the vessel is departing from a port so as to facilitate the crew onboard the towing vessel to observe the abnormal change of towed object during the towage. If it is unfeasible, size may be reduced properly. Barges not carrying deck cargo, if possible, are to meet this requirement as far as possible.

Section 5 Drainage Facility and Scuppers

2.5.1 In general, drainage facilities are to be fitted in cargo holds, machinery spaces and watertight tanks to provide enough buoyancy and floatability for the towed vessel.

2.5.2 Bilge pumps, ballast pumps or other discharge pumps and its piping and suction are to be kept in an effective condition during the towage.

Strum boxes at the bilge suction of all holds are to be equipped with reliable protecting devices.

2.5.3 If the drainage equipment has not been installed onboard the towed vessel, at least one portable discharge pump with independent power supply is to be provided. The lift and capacity of the discharge pump is to be determined in accordance with the dimension and the hold capacity of the towed vessel.

2.5.4 All inlet and outlet valves on the towed vessel are to be closed and the handles are to be lashed by wire or other effective measures against loosening except those necessary for the safety of the towed vessel and crew's accommodation.

Section 6 Anchoring Equipment

2.6.1 Unless rendered impractical due to the design or conditions, anchoring equipment is to be provided on towed object to hold it in severe weather conditions and chain cable or wire rope is also to be attached, it is so arranged to facilitate for release in an emergency by the personnel onboard or boarding the towed object.

2.6.2 Where the anchoring equipment has been provided on the towed object, it is to be kept in an effective condition and readily available.

2.6.3 Where the anchoring equipment has not been provided on the towed object, at least one anchor is to be temporarily provided for the towage and meet with the following requirement:

$$W = 7 \times \Delta^{2/3} \text{ kg}$$

where: W — the weight of anchor, in kg;
 Δ — the towing displacement, in t.

The diameter of the chain cable is to be suitable for the weight of anchor and the length of chain cable is not less than 5 shots. The chain cable may be substituted by wire rope, which the minimum breaking load is not to be less than and the length is not less than 1.5 times of those of the chain cable.

2.6.4 The anchor, including the temporarily provided one is to be capable of quickly dropping.

Section 7 Rudder and Propeller

2.7.1 Where rudder equipment is intended to use during the towage operation, the steering gear is to be in a sound working condition.

2.7.2 Where the rudder equipment is not intended to use during the towage operation, the rudder blade is to be fixed in the amidship position. If the rudder blade is required to fix at a certain angle, it is to be consulted with tug master. If it is necessary to use the rudder or to change the rudder angle during the voyage which has been fixed in a certain position, it is to be re-fixed after that.

2.7.3 For the towed object installed with auxiliary propulsion plant, but unnecessary to use during the towage, measures are to be taken to prevent the propulsion plant from turning.

2.7.4 Where the towed object is a motor vessel losing power due to sea damage or engine damage, the rudder blade is to be fixed in the amidship position and measures are to be taken to prevent the propulsion plant from turning.

Section 8 Lights, Shapes and Sound Signals

2.8.1 The towed vessel is to be exhibited with the following lights and shapes:

(1) two side lights;

(2) when the length of the towage exceeds 200 meters, a stern light and a diamond shape exhibited in a conspicuous position.

2.8.2 The design and location of lights, shapes and sound signals on the towed object are to comply with the requirements of the International Regulations for Preventing Collision at Sea, 1972. If practicable, a duplicate system of lights is to be provided.

2.8.3 The towed object normally unattended is to be provided with sufficient power supply for the navigation lights to last for the duration of the towage to the destination port.

2.8.4 For the towed object normally attended, audible signal is to be given as the visibility is not sufficient according to the provisions of Regulation 35 of the International Regulations for Preventing Collisions at Sea, 1972.

Section 9 Boarding Facilities

2.9.1 For boarding the towed object from the towing vessel or other vessels, steel ladders or rungs are to be fitted on each side of the towed vessel. Rope ladders may be considered if safety means for fastening and securing the ladders are taken.

Section 10 Additional Requirements for Towed Vessels Normally Attended

2.10.1 The number of riding crew onboard the towed vessel is to be as far as possible limited to the minimum as necessary.

2.10.2 The towed object normally attended is to be provided with adequate accommodation, sanitary facilities and cooking equipment and stored sufficient quantities of provisions, fresh water and fuel oil to satisfy with the crew's need during the towage.

2.10.3 When the towed object normally attended is being towed, communication equipment is to be provided onboard for effective intercommunication between the towed vessel and the towing vessel. If portable VHF radiotelephone apparatus is provided, the required quantity is to be two sets with two sets of storage batteries with sufficient power supply for the voyage.

2.10.4 The towed object normally attended is to be at least provided with following life - saving appliances:

- (1) an inflatable liferaft with the capacity of accommodating all persons onboard is to be provided on each side; if the distance between embarkation space and water surface exceeds 4.5 m, liferaft davits are to be provided, unless rendered impractical due to the design or conditions of the towed object;
- (2) four lifebuoys, where two lifebuoys provided with self-igniting lights and two lifebuoys provided with buoyant lifelines;
- (3) one rope ladder is to be provided where liferaft is stowed;
- (4) one life-jacket for each person;
- (5) six rocket parachute flares, six hand flares and one portable signaling flashing light; and
- (6) four portable line-throwing appliances.

Section 11 Lashing and Securing of Cargo and Equipment

2.11.1 Cargoes carried on the towed object are to be reliably lashed and secured during the towage in order to prevent their movement, damage or effect on the stability of towed object.

2.11.2 Where the towed object is the facility of floating dock and engineering ship, such as floating crane, dredging equipment, pipe-laying facility and pile driver, etc., the equipment and machinery on deck or in hold are to be lashed and secured.

Section 12 Fire-fighting Appliances

2.12.1 Portable fire-fighting appliances are to be provided onboard the towed object normally attended during the towage according to the type of towed object and characteristic of cargo carried. Portable foam fire-extinguisher is generally to be provided.

Section 13 Towing Points

2.13.1 The towing equipment, such as towing point (towing eye plate or towing bollard), chock (fairlead), towing eye, shackle, etc. is to comply with the meteorological criterion for towing environment and is to have the sufficient capability to maintain the towing direction. The strength of towing point is to be determined by the dimension and configuration of the towed object and the towage speed.

2.13.2 There are at least two sets of towing points (towing eye plate or towing bollard) and the fairlead which is capable of accommodating the chafing chain on the towed object. The proper bollards or mooring equipment on towed vessel may also be taken as towing point. The fairlead is to be so shaped as to prevent excess stress in the links of chafing chain.

2.13.3 Means are to be taken to prevent wear and tear for the fairlead or the area in adjacent to fairlead where is easily worn out onboard the towed object connected with the main towline by wire rope bridle/chain bridle and delta eye plate.

2.13.4 Towline attachments are to be designed to resist the towline pull from any likely direction and fairlead is to be used if necessary. The design and arrangement of the towing fittings are to be taken into account of both normal and emergency conditions.

Section 14 Measures for Prevention of Pollution

2.14.1 To reduce the contamination risk, the fuel oil carried on the towed object is to be as the minimum as possible, the total amount is limited to that is required for the safety and normal towage operation.

Section 15 Miscellaneous

2.15.1 For the towed object normally unattended, adequate amount of provisions, fresh water and fuel oil are to be provided for the emergency use, where necessary (long-distance voyage/temporary accommodation cabin, etc.).

CHAPTER 3 TOWED OBJECT -- MOBILE OFFSHORE DRILLING UNIT AND OTHER OFFSHORE INSTALLATIONS

Section 1 General

3.1.1 This Chapter applies to the towage operation for towed mobile offshore drilling units and other offshore installations under the standard environmental conditions of the towage at sea.

3.1.2 In addition to complying with the requirements of this Chapter, the ocean towage for mobile offshore drilling units is to be in compliance with the relevant provisions of Chapter 2.

3.1.3 For the mobile offshore drilling units, other offshore installation and the similar structure, and installation and similar structure constructed according to Rules for Classification of Mobile Offshore Drilling Units and Rules for Classification of Floating Offshore Installations, or other equivalent standards, the towage assessment is to be made at least under the standard environmental conditions for ocean towage, and the towage is to be carried out better than such condition.

3.1.4 If the mobile offshore drilling unit, other offshore installations and similar structure have obtained the safety certificates/survey certificates issued by ISC and verified that the structure, stability and safety equipment are in compliance with those described in the certificates, it is to be regarded that they are in a condition fit for being towed.

3.1.5 For self-elevating drilling unit, the lowering of hull, pile-drawing, the commencement of towage operation and pile-stabbing to the sea bottom when arriving at the destination are to be carried out in a sound sea condition.

3.1.6 Duty and lookout are to be enhanced for the riding crew onboard the mobile offshore drilling units, other offshore installations and similar structures normally attended during the towage.

3.1.7 For the mobile offshore drilling units normally attended during the towage, the structure, watertight closing appliances, towing equipment and the securing conditions of legs and derricks are to be inspected periodically by the riding crew and the results are to be reported to the towing master or tug master.

3.1.8 An immersion suit is to be provided for each person onboard the mobile offshore drilling units being towed in cold sea areas in winter, in addition to complying with the provisions of Chapter 2 for life-saving appliances.

3.1.9 In addition to the relevant requirements of Sections 2, 3, 4, 5, 8, 9, 11, and 13 of Chapter 2, the ocean towage for surface structures or other offshore installations is to comply with the requirements of this Chapter.

Section 2 Intact Stability and Speed

3.2.1 It is to be ensured that the intact stability of towed mobile offshore drilling units and other offshore installations is to satisfy the relevant requirements of the flag State Administration and the approved operation manual. If there is no requirement by the Administration, at least the following requirements are to be complied with:

- (1) initial metacentric height GM_0 is not to be less than 0.3 m;
- (2) the vanishing angle of righting lever curve is not to be less than 35° , and the area covered by righting lever curve is not to be less than 0.10 m-rad;
- (3) the ratio of areas covered by righting lever curve and wind heeling curve to the second intersection point θ_2 or angle of flooding θ_j (whichever is smaller) is not to be less than 1.4, that is $A + B \geq 1.4 (B + C)$. (See Figure 3.2.1)

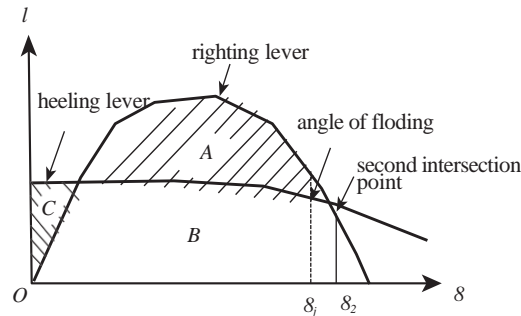

Figure 3.2.1

where: wind pressure lever l is to be calculated according to the following:

$$l = \frac{0.5\rho V^2}{9810\Delta} \sum C_h C_s A Z \quad (\text{m})$$

- where: ρ — density of air, taken as 1.22 kg/m^3 ;
- V — design wind velocity, in m/s, for unrestricted service area and offshore service area, the minimum wind velocity is taken as 36 m/s (70 kn); For coastal service area, 30.9 m/s (60 kn) is to be taken; For sheltered water service area, 25.8 m/s (50 kn) is to be taken. For long-distance towage at unrestricted service area, wind velocity is taken as 51.5 m/s (100 kn) based upon the route and weather conditions;
- Δ — displacement, in t;
- C_h — height coefficient of wind member, depending on the height h (m) above design waterline of the area center of the member, taken from Table 3.2.1(1);
- C_s — shape coefficient of wind member, taken from Table 3.2.1(2);
- A — projected area of wind member vertical to the direction of wind velocity under the upright or heeled condition, in m^2 ;
- Z — vertical distance from wind area center of the structural member to resistance center of ship side below waterline, where the resistance center may be taken as half of the design draught.

Value of Coefficient C_h Table 3.2.1(1)

Height above waterline (m)	C_h	Height above waterline (m)	C_h
0~15.3	1.00	137.0~152.5	1.60
15.3~30.5	1.10	152.5~167.5	1.63
30.5~46.0	1.20	167.5~183.0	1.67
46.0~61.0	1.30	183.0~198.0	1.70
61.0~76.0	1.37	198.0~213.5	1.72
76.0~91.5	1.43	213.5~228.5	1.75
91.5~106.5	1.48	228.5~244.0	1.77
106.5~122.0	1.52	244.0~256.0	1.79
122.0~137.0	1.56	Above 256	1.80

Value of Coefficient C_s **Table 3.2.1(2)**

Configuration	C_s	Configuration	C_s
Spherical	0.4	Drilling derrick	1.25
Cylindrical	0.5	Wires	1.2
Large flat surface (hull, deckhouse, smooth area below the deck)	1.0	Exposed beams and girders below the deck	1.3
		Small parts	1.4
Grouping deckhouses or similar structures	1.1	Isolated configuration (crane, beam, etc.)	1.5

3.2.2 The mobile offshore drilling unit is to have an appropriate trim by the stern during the towage. The trim by stern of self-elevating drilling units is recommended to be less than 0.3 m, and that of semi-submerged drilling units is recommended not to be less than 0.4 m.

3.2.3 The mobile offshore drilling units are to be towed at a proper speed during the towage, it is not less than 4 kn in the static water. For the self-propelled semi-submersible drilling unit, if the main propulsion machinery is running during the towage, the superimposed towage speed is not to be greater than 10 kn.

3.2.4 The towing vessel is to have a reserve towing power for braking and safe maneuvering the mobile offshore drilling units, and the safety braking force is to be determined by the wind velocity of 20 m/s.

Section 3 Free Surface of Liquid Tanks and Closure of Openings

3.3.1 It is recommended that all liquid tanks on the towed object are to be in loaded or in ballast condition during the towage. Otherwise, towage stability calculation involving the effect of free liquid surface is to be submitted according to actual loading condition.

3.3.2 The various weathertight openings on the mobile offshore drilling unit are to be closed.

3.3.3 For the self-elevating drilling unit, when the legs are lowered, unit body are lifted or lowered and the unit is commenced to tow, it is to be operated in compliance with the provisions of the approved operation manual. Manholes on caissons, suction pipes, blow pipes and sea inlet valves are to be kept closed watertightly.

Section 4 Lashing and Securing

3.4.1 All movable or portable equipment, tools and stores are to be required to be lashed and secured effectively according to the requirements of the approved operation manual.

3.4.2 The movable apron plating for the helicopter on the mobile offshore drilling unit is to be removed and secured prior to the towage. Movable gridiron or platform plating fitted in way of wellhead is also to be removed and secured for the towage.

3.4.3 The drill rods, collars and casings between the pipe racks on the deck are to be lashed, in addition, means are to be taken for both ends of pipe racks so as to prevent longitudinal sliding of the pipes and drill rods.

3.4.4 The upper and lower wedges of the wedging system on the legs of self-elevating drilling unit are to be closely attached to the legs and the unit body so as to prevent the legs from moving during the towage.

CHAPTER 4 TOWING VESSEL

Section 1 General

4.1.1 A towing vessel with sufficient bollard pull is to be selected based on the configuration, main dimension, towing distance, weather and sea conditions of route as well as ensure the safety towage speed. The types, requirements and conditions of multiple towages may be referred to in Appendix 5.

4.1.2 The towing vessel is to be provided with valid certificates and information as follows:

- (1) certificates applicable to the towing route;
- (2) stability information of towage;
- (3) arrangement of towage operation;
- (4) certificate of towing equipment and gears;
- (5) certificate of bollard pull test for the towing vessel. For the bollard pull test, reference may be made to Appendix 3 or the recognized standards and GB standards.

4.1.3 The bollard pull of towing vessel is to be suitable for the safety towage for towed object. The estimation of total towing resistance may be referred to Appendix 2. Where the tow is intended to be carried out by the stern, the bollard pull required by the towed object is generally to be increased 20% due to the changed linear or the difficulty for keeping the steady course of the towed object.

4.1.4 Where the towed vessel has not obtained the certificate of bollard pull test, it may be estimated as 1 ton per 100 hp according to the rated output of main propulsion machinery on the towing vessel. If such rated output can not be determined, it is to be reduced by 1% per year of the output marked on nameplate of the main propulsion machinery.

4.1.5 The towage speed of a towing vessel in static water is to comply with the following requirements:

- (1) not less than 6 kn for towed object in ship-type;
- (2) not less than 5 kn for towed object with special linear, such as floating dock, crane carrier, etc.) or semi-submersible drilling unit;
- (3) not less than 4 kn for self-elevating drilling unit and other surface structure.

4.1.6 The towing vessel engaged in unrestricted service area is to be equipped with at least two main engines and two sets of steering gears.

4.1.7 Inspection of the towline is to be carried out on completion of each towage operation. The results of inspection are to be recorded in the towing log as a basis for future inspection and maintenance programs.

4.1.8 The towing equipment is to be inspected before each towage operation. The towline is to be renewed if it is found that the reduction in cross sectional area due to wear, abrasion, corrosion and broken wires exceeds 10% or there is severe kinking, crushing or other damage resulting in distortion of the rope structure, as well as end sockets or other towline terminations such as thimbles, etc, are damaged, deformed or significantly corroded.

4.1.9 The towing vessel is to keep a towing log (the proposed form given in Appendix 4) in accordance with required contents.

4.1.10 The engine log for main propulsion machinery and auxiliaries required for the towage is as a maximum to contain information related to running hours and unscheduled events.

4.1.11 The crew are to be manned onboard towing vessels in accordance with the relevant provisions of the flag State Administration. If such provisions are under the relevant manning requirements in STCW Convention, more crew may be required for the multiple towage operation.

Section 2 Communication Equipment

4.2.1 The communication equipment onboard the towing vessel during towage operation is to meet those requirements of the Administrations in departure and destination ports.

4.2.2 For the towed object normally attended during the voyage, at least two portable VHF two-way radiotelephones and one daylight signaling lamp are to be equipped onboard the towing vessel. If the towed vessel is boarded for inspection or other reasons during the towage, at least one VHF two-way radiotelephone is to be equipped for the boarding crew.

Section 3 Equipment for Transfer of Personnel

4.3.1 At least one proper workboat with propulsion motor is to be equipped on the towing vessel for navigating in the unrestricted service area to transfer personnel and equipment to the towed vessel.

4.3.2 If the dedicated workboat with propulsion machinery is of an inflatable type, it is to be provided with sufficient space for convenient operation and release and the means for safety use.

4.3.3 Protective means are to be taken if the inflatable workboat for personnel is used to transfer the equipment to the towed object.

Section 4 Miscellaneous

4.4.1 The navigational equipment are to meet the towage operation requirements of the flag State Administrations in departure and destination ports.

4.4.2 During the towage, the towing vessel is to be manned with crew in accordance with STCW Convention and provided with sufficient fuel oil, fresh water, provisions and other spare parts as well as adequate stores according to weather and sea conditions on the route and the towing voyage.

4.4.3 Life net is to be provided on both sides at amidship of the towing vessel to be available for the personnel overboard to board the vessel. During the towage, the life net may be laid on deck, however, is to be readily available.

4.4.4 The towing vessel is to be provided with a quick-cutter for towlines or other emergency release unit in adjacent to the towing winch.

4.4.5 The towing vessels are to be equipped with arrangements to prevent athwartship pull of the towlines.

CHAPTER 5 TOWING EQUIPMENT AND GEARS

Section 1 General

5.1.1 All the towing equipment on the towing vessel are to be designed according to the approved recognized standards based on their power of main propulsion machinery. The relevant certificates or documents are to be kept onboard.

5.1.2 The towing equipment on the towed vessel are to be designed according to the recognized standards based on their dimension, facilities, number of cargoes carried, towing environment and the potential maximum load.

5.1.3 The certificates of testing for towing gears, such as towline, spare and emergency towlines, short pennant, wire rope bridle/chain bridle, delta eye plate, shackle, towing ring, etc., are to be submitted for review.

5.1.4 The strength calculations of towing points on the towed object, such as towing eye plate or towing bollard, fairlead or other similar devices and the supporting structures are to be submitted for review.

Section 2 Towing Winch

5.2.1 The tension of the outermost towline layer on the drum of the selected towing winch is to be equal to or greater than the bollard pull of the towing vessel. The strength, dimension of the towing winch, including supports are to be capable of withstanding the breaking load of main towlines acting on the uppermost position of the deck without permanent deformation.

5.2.2 The towing winch brakes are to be selected according to the recognized standards. In general, a static holding capacity is to be taken as 1.1 times the breaking load of the towline.

5.2.3 In addition to the main braking system of the winch , it is to be provided with an emergency braking system which the braking power of innermost towline layer on the drum is at least twice the static bollard pull of the towing vessel, without the ordinary power source from the winch for the towing vessel operation.

5.2.4 It is recommended that the winch is to be provided with an indicator for measuring the tension of the towline onboard new-built towing vessel navigating in unrestricted service area. The indicator is to be capable of recording, as a minimum, to record the mean tension and the tension peaks, meanwhile, alarming the overload and indicating the released length of the towline, all the information are to be displayed in the bridge.

5.2.5 The winch is to be designed to allow drum release in an emergency from the bridge when braking, hauling or recovery operation. Such emergency release is to be possible under all conditions, even in the event of failure of the normal power supply. The maximum delay from the moment the release is actuated to the drum being disengaged is 10 s.

5.2.6 The winch is to be so designed as the automatic constant tension type that the brake will not be inoperative under the emergency release of towlines and ensure the winch is working under the preset tension.

5.2.7 The main power supply source of winch is to be so designed as the fail-safe type that the brake will not be disconnected completely when the towline or emergency towline is released or the power supply is in failure.

5.2.8 When the winch is braked, it is to prevent the wire ropes from being tightened up instantaneously and snatching on the towline.

5.2.9 The connection of the end of towline to the winch drum is not to be firm, with the capacity not less than 98 kN, but not more than 15% of the breaking load of the towline, so that the line can be smoothly released from the drum in the emergency.

5.2.10 The innermost towline layer in the winch drum is to be capable of reeling at least 50 m or is to be maintained sufficient friction force for the towage operation by the other method, and sufficient length of towline to pay out in case of failure operation to prevent skidding.

5.2.11 Towing winch is to be provided with means to spool the towline effectively on the drum.

5.2.12 Pressure relief valves are to be provided for hydraulic towing winch to ensure that its working pressure will not exceed the rated one.

Section 3 Towing Equipment and Gears

5.3.1 Strength requirements of towlines and other towing equipment:

(1) The main towline and spare towline are to be of wire ropes and their minimum breaking loads are to be determined by the bollard pull (BP) of towing vessel and towing environment as Table 5.3.8. For the towage carried out in the benign areas and the towing period less than 24 h, polyamide rope may be used as main towline with the minimum breaking load is to be 1.37 times the wire rope. If synthetic fibre rope is used as main towline, its minimum breaking load is to be 1.25 times that of the wire rope.

(2) The main towline and spare towline are to be reeled on their independent drums as practical as possible for the towing vessel with the towing period more than 72 h. If impracticable, the spare towline is to be stored in a position where it can be safely and expediently transferred to the main towline drum. For the towage voyage over three weeks duration in unrestricted service area, an extra spare towline is recommended to provide, it can be so arranged on the second winch drum or the drum of the first spare towline as not to damage the towline. In case of two towed objects, whereby two towlines (main towline and spare towline) are to be connected independently, an extra spare towline is to be provided onboard, arranged as specified above.

(3) The capability of spare towing equipment is to be the same as that of main equipment.

(4) The minimum breaking load of all connecting items, such as shackles, rings, delta eye plates, etc. is not to be less than 1.5 times the maximum breaking load of towline to be used.

(5) The connecting items, such as towing hooks, shackles, rings, delta eye plates are to hold the testing certificates, the testing loads are to be as follows:

testing load = $2.0 \times BP$ (kN), for $BP < 392$ kN;

testing load = $1.0 \times BP + 392$ (kN), for $BP \geq 392$ kN.

5.3.2 The shackles are to be of bolt type with nuts and split pins.

5.3.3 The wire rope eye or loop of the terminations of towline and wire rope bridle/chain bridle is not to be made by hand-splicing method, but the spelter sockets or other mechanical connections are to be used. Reinforced thimbles or equivalent measures are to be provided for the wire rope eye at the terminations of towline.

5.3.4 The towline, short pennant, and wire rope bridle/chain bridle made of steel are to be well lubricated. The breaking strength of each wire rope bridle/chain bridle is not to be less than that of the main towline.

5.3.5 Where the duration of towage operation exceeds 72 h, a short pennant normally with the length of 10 ~ 30 m is to be applied for the technical purpose to connect the towing vessel with the towed object. Longer pedant may be used in the special case. The minimum breaking strength of short pennant is to be equivalent to that of the main towline and the wire rope eyes at the terminations of steel short pennant are to comply with the requirements of 5.3.3. If fibre rope pennant is used, its breaking load is to meet the following:

- (1) twice the breaking load of towline, for towing vessel with bollard pull < 491 kN;
- (2) 1.5 times the breaking load of towline, for towing vessel with bollard pull > 981 kN;
- (3) linearly interpolated between 1.5 and twice the towline, for towing vessel with bollard pull of $491 \sim 981$ kN.

5.3.6 Winch is to be applied during the ocean towing. The towing hook is generally not to be used except the short-voyage within coastal service area and sheltered water service area.

5.3.7 In general, chafing measures are to be taken for the towing gear in way of chafing area as appropriate, such as chafing chain. The chafing chain is to extend at least 3 m out of the fairlead from towing point and to be provided with stud link.

5.3.8 The provision of towing equipment is not to be inferior than the requirements of 5.3.8. Sufficient spare parts are to be provided for the towing vessel in order to compose a complete set of spare towing arrangements unless it is impracticable.

5.3.9 All wire ropes in use are to have the same lay.

5.3.10 The towed object is to be set the towing points (towing founder plate or towing bollard) with their strength based on pull as required and the intended towing route so as to ensure the safety towage under the environmental conditions. Spare towing eye plate or towing bollard is to be provided onboard the towed object.

(1) The ultimate strength of towing points, such as towing eye plate or towing bollard and hull supporting structure is capable of withstanding a load at least 1.3 times the minimum breaking load of the main towline which is determined by the bollard pull as required.

(2) The ultimate strength of emergency towing point is at least to exceed the breaking load of the main towline.

Provision of towing equipment

Table 5.3.8

Towing hour (h)	≥ 72	24 ~ 72 ⁽¹⁾	≤ 24 ⁽¹⁾
Towing winch	provided	provided	provided ⁽²⁾
Drum	1	1	1
Main towline	1	1	1
Spare towline ⁽³⁾	1	1	—
Min. breaking load (<i>MBL</i>) <i>BP</i> (above 883 kN)	$2.0 \times BP$	$2.0 \times BP$	$2.0 \times BP$
Min. breaking load (<i>MBL</i>) <i>BP</i> (392~883 kN)	$(3.8-BP/491) \times BP$	$2.0 \times BP$	$2.0 \times BP$
Min. breaking load (<i>MBL</i>) <i>BP</i> (below 392 kN)	$3.0 \times BP$	$2.0 \times BP$	$2.0 \times BP$
Length of main towline (m)	$BP/MBL \times 1800$	$BP/MBL \times 1200$	$BP/MBL \times 1200$
Min. length of main towline (m)	650	500	500
Short pennant ⁽⁴⁾	2	2	2
Delta eye plate ⁽⁴⁾	1	1	1
Wire rope bridle/chain bridle ⁽⁴⁾	1	1	1
Shackle ⁽⁴⁾	7×2	7	7

Notes: (1) If it is in benign area, otherwise, provided according to the requirements for the towage more than 72 h;

(2) Winch is to be used for ocean towing. In general, towing hook is not to be used except the short voyage within coastal service area and sheltered water service area;

(3) An emergency polyamide rope is to be provided for the towage operation not exceeding 24 h, and its minimum breaking load is to be suitable for the bollard pull, the length is not less than 200 m;

(4) It is the optional equipment. Short pennant is to be provided according to the requirement for connection of towline and delta eye plate. Delta eye plate, wire rope bridle/chain bridle and shackle are to be provided according to the towed object.

5.3.11 The towing points (towing eye plate and towing bollard) are to be arranged in way of reinforced structural members, i.e. intersection of transverse and longitudinal bulkheads or nodes with sufficient strength below the deck, and suitable reinforcement is to be carried out for the structure, if necessary. The towing eye plate is to be of the quick-release type and the fairlead is to be so designed that it is capable of accommodating the chafing chain.

5.3.12 Appropriate distance between towing point or towing eye plate and chock or fairlead is to be kept to facilitate the operation of the towing equipment.

5.3.13 If the wire rope bridle is planned to use again during the towage, a bridle recovery system is to be provided, one terminate of the recovery bridle is to be connected to the dedicated ring on delta eye plate by shackle and another one is to be secured on the winch of the towed object. The recovery bridle is to be ensured to recover the wire rope bridle/chain bridle and delta eye plate, with the breaking load is not to be less than three times the weight of wire rope bridle/chain bridle and the minimum breaking load not to be less than 196 kN.

The arrangement of recovery bridle is as shown in Figure 5.3.13.

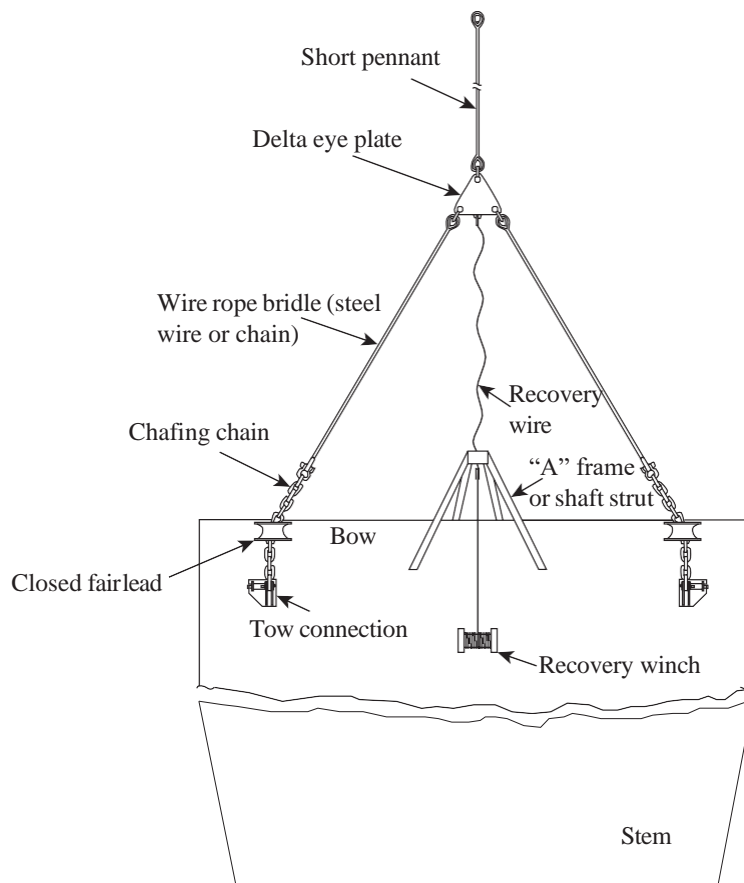

Figure 5.3.13 Arrangement of wire rope bridle/chain bridle recovery system

5.3.14 In order to be connected with the towing vessel reliably and quickly in an emergency, an emergency towline is to be provided onboard the towed object normally unattended. One end of the line is to be connected to the emergency towing point and the other to the lead line with adequate length and strength of which the end is connected to a bright red buoy with adequate buoyancy.

5.3.15 In general, synthetic fibre material with buoyancy is to be used for lead line of emergency towline. The length is not to be less than that of the vessel and the breaking load is not to be less than 294 kN.

5.3.16 The emergency towline and lead line are to be extended to the outside of bulwark and lashed with bulwark or rails at appropriate intervals. The distance between the towed object and buoy is not to be less than 50 m. The emergency towline may be unlashed quickly. If necessary, an additional extension wire is to be provided between the emergency towline and the float line.

The arrangement of emergency towline is as shown in Figure 5.3.16.

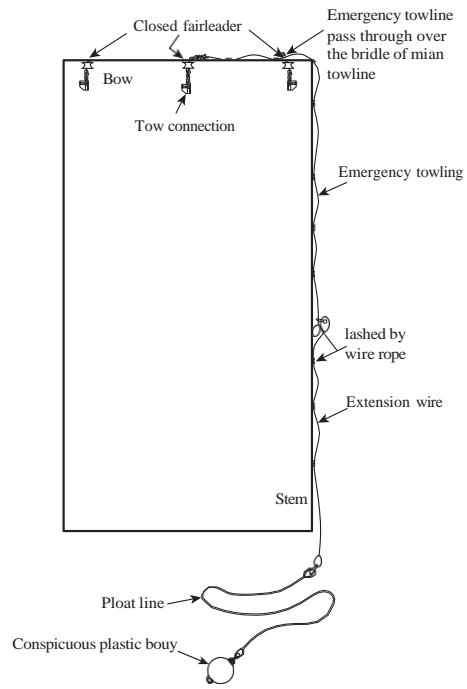

Figure 5.3.16 Arrangement of emergency towline on towed object normally unattended

Appendix 1 Strength standard of supporting members and lashing components

1. General

1.1 Where the towed object is an ocean vessel with normal scale ratio, the lashing and securing force are to be calculated in accordance with the requirements of securing equipment for containers in ISC Rules for Classification of Sea-going Steel Ships.

1.2 Where the towed object is a barge, engineering ship or other surface structure, the lashing and securing force is to be calculated as the approximate method in 2.

1.3 The above-mentioned calculation for lashing and securing force is based on the motion analysis of ocean navigation, model testing method can be also taken.

1.4 The recommended default motion criteria in 3 may be accepted for those determined neither by motion analysis nor by model testing.

1.5 Where the planned towage time (i.e. voyage distance, average velocity) is less than the period of time for which the weather conditions can be reliably forecasted, or towage is carried out in specified sea areas of smooth sea or in specified season, it is acceptable that the ship's motion load may be obtained from ship's seakeeping analysis and quasi-static analysis under the worst sea conditions possibly encounter calculated by the recognized software.

1.6 The strength calculation for lashing equipment is carried out according to the approximate method in 4. If it is lashed by port and starboard symmetry or fore and aft symmetry, calculation may be made only for one side, otherwise, is to be made separately.

2. Calculation of forces acting on cargo carried by towed vessel (towed object)

2.1 Forces acting athwartships

The force acting athwartships F_y on a cargo and parallel to the deck is to be obtained from the following formula:

$$F_y = MA_y + F_q + F_w \quad \text{kN}$$

where: M — mass of cargo, in t;

A_y — acceleration acting athwartships, in m/s^2 ;

F_q — wind force, in kN, according to the side projection area of cargo, it is to be calculated according to the following standard:

1 kN/m^2 (unrestricted service and offshore service areas);

0.85 kN/m^2 (coastal service area);

0.70 kN/m^2 (sheltered water service area);

F_w — impulse force of spray sea water, in kN; only side projection areas of part of cargo under 2.0 m height distanced from freeboards deck are to be calculated and the following standards are employed:

1 kN/m² (unrestricted service and offshore service areas);
 0.7 kN/m² (coastal service area);
 0.5 kN/m² (sheltered water service area);

A_y — acceleration acting athwartships is calculated as follows:

$$A_y = r_\varphi \cdot \cos \beta \cdot \frac{\varphi_0 \pi}{180} \left(\frac{2\pi}{T_\varphi} \right)^2 + g \cdot \sin \varphi_0 \quad \text{m/s}^2$$

where: r_φ — distance from the centre of mass of cargo to the assumed centre of rotation at waterline, in m, as shown in Figure 2.1;
 β — angle, as shown in Figure 2.1;
 φ_0 — maximum rolling angle in°, in general, 15° is taken for the floating body;
 T_φ — rolling period, in s, calculated as follows:

$$T_\varphi = 1.1B / \sqrt{GM}$$

where: GM is the initial metacentric height, in m; B is the breadth of the vessel, in m. If there is no detailed GM data of the towed object, the following approximate calculation may be taken:

$$T_\varphi = 1.7\sqrt{B+20}, \text{ but not more than } 10\text{s};$$

g — gravitational acceleration, to be taken as 9.81m/s².

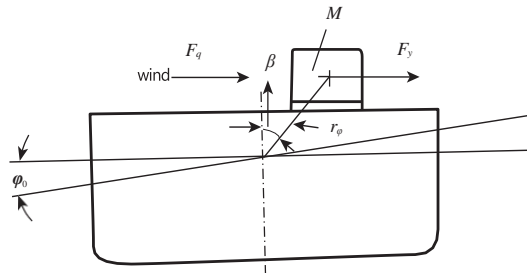

Figure 2.1

2.2 Forces acting in the longitudinal direction

The force acting in the longitudinal direction F_x on cargo and parallel to the deck is to be calculated as follows:

$$F_x = MA_x + F_q + F_w \quad \text{kN}$$

where: A_x — longitudinal acceleration, in m/s²;
 M — mass of cargo, in t;
 F_q, F_w — the same as in 2.1, calculated according to the projection area of amidships section of cargo, and the longitudinal acceleration A_x is to be calculated as follows:

$$A_x = r_\psi \cdot \cos \beta \cdot \frac{\psi_0 \pi}{180} \left(\frac{2\pi}{T_\psi} \right)^2 + g \cdot \sin \psi_0 \quad \text{m/s}^2$$

where: r_ψ — distance from the centre of mass of cargo to the assumed centre of rotation at waterline, in m, as shown in Figure 2.2;
 β — angle, as shown in Figure 2.1;
 ψ_0 — maximum pitching angle in°, in general, 5° is taken for the floating body;
 T_ψ — pitching period, in s, may be taken as 10s if there is no detailed data;
 g — the same as in 2.1

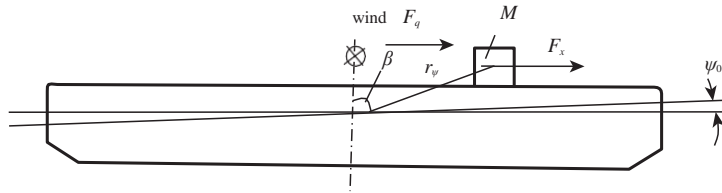

Figure 2.2

2.3 Forces acting perpendicular to the deck

The force acting perpendicular to the deck F_z on cargo or deck supporting member is to be obtained from the following formula:

$$F_z = M(g \pm a) \quad \text{kN}$$

where: M, g — The same as in 2.1;
 a — vertical acceleration, in m/s^2 , $a = 3.75e^{-0.0033L}$, but unnecessary to be more than 3 m/s^2 ;
 L is the length of ship, in m.

Note: $F_z(+)$ = $M(g + a)$ is taken for the force on the deck supporting members;

$F_z(-)$ = $M(g - a)$ is taken for the force on the lashing components.

3. Default motion criteria

3.1 If neither a motions study nor model tests are performed, then for standard configurations and subject to satisfactory marine procedures, the following motion criteria may be acceptable.

Default Motion Criteria

Table 3.1

Natures of transportation	Case	LOA (m)	B ⁽¹⁾ (m)	L/B ⁽¹⁾	Block coeff.	Full Cycle Period(s)	Single amplitude		Heave
							Roll	Pitch	
Unrestricted	1	>140 and >30	n/a	< 0.9	10	20°	10°	0.2g	
	2	>76 and >23	n/a	any	10	20°	12.5°	0.2g	
	3	≤76 or ≤23	≥2.5	< 0.9	10	30°	15°	0.2g	
	4			≥ 0.9		25°			
	5	≤76 or ≤23	<2.5	< 0.9	10	30°	30°	0.2g	
	6			≥ 0.9		25°	25°		

Natures of transportation	Case	LOA (m)	B ⁽¹⁾ (m)	L/B ⁽¹⁾	Block coeff.	Full Cycle Period(s)	Single amplitude		Heave
							Roll	Pitch	
Weather restricted operations in non-benign areas for a duration < 24 h (see 3.2.4). For L/B < 1.4, use unrestricted case	7	Any		≥2.5	Any	10	10°	5°	0.1g
	8	Any		<2.5, ≥1.4	Any	10	10°	10°	0.1g
Weather restricted operations in benign areas for a duration < 24 h (see 3.2.5). for L/B < 1.4, use unrestricted case	9	Any		≥2.5	Any	10	5°	2.5°	0.1g
	10	Any		<2.5, ≥1.4	Any	10	5°	5°	0.1g
Sheltered water transportations (see 3.2.6). For L/B < 1.4, use unrestricted case	11	Any		≥1.4	Any	Static	Equivalent to 0.1 g in both directions		0.0
Independent leg jack-ups, ocean tow on own hull	12	n/a	>23	<1.4	n/a	10	20°	20°	0.0
Independent leg jack-ups, 24-hour or location move	13	n/a	>23	<1.4	n/a	10	10°	10°	0.0
Nat-type jack-up, ocean tow on own hull	14	n/a	>23	<1.4	n/a	13	16°	16°	0.0
Nat-type jack-ups, 24-hour or location move	15	n/a	>23	<1.4	n/a	13	8°	8°	0.0

Note(1) B – maximum moulded waterline breadth;

L – waterline length;

n/a – not applicable;

Block coefficient – 0.9 is the cut-off between barge-shaped hulls (>0.9) and ship-shaped hulls.

3.2 The default motion criteria shown in 3.1, are only be applied in accordance with the following:

3.2.1 Roll and pitch axes are to be assumed to pass through the centre of floatation.

3.2.2 Heave is to be assumed to be parallel to the global vertical axis. Therefore the component of heave parallel to the deck at the roll or pitch angles shown above is additive to the forces caused by the static gravity component and by the roll or pitch acceleration.

3.2.3 Phasing is to be assumed to combine, as separate load cases, the most severe combinations of

- roll + heave
- pitch + heave

3.2.4 For Cases 7 and 8, the departure is to be limited to a maximum of Beaufort Force 5, with an improving forecast for the following 48 h. The voyage duration including contingencies, is not to be greater than 24 h.

3.2.5 For Cases 9 and 10, the criteria stated is given as general guidance for short duration barge tows and vessel transports. The actual criteria are to be taken into account the nature of the vessel or barge and cargo, the voyage route, the weather conditions which may be encountered, the shelter available and the weather forecasting services to be utilized.

3.2.6 For Case 11, the design loading in each direction is to be taken as the most onerous due to:

- 0.1 g static load parallel to the deck, or
- the static inclination caused by the design wind, or
- the most severe inclination in the one-compartment damage condition.

4. Balance of force and moment

Balance calculation is to be made separately for the check of transverse sliding, transverse tipping and longitudinal sliding.

4.1 Transverse sliding

The balance of transverse sliding is to meet the following formula:

$$F_y \leq \mu F_z(-) + \sum CS_i (\mu \cdot \sin \alpha + \cos \alpha \cdot \sin \beta)$$

where: F_y — force acting athwartships, in kN, to be calculated as 2.1;

$F_z(-)$ — force acting perpendicular to the deck, in kN, to be calculated as 2.3;

μ — friction factor, to be taken as follows:

$\mu = 0.3$ for steel-timber or steel-rubber;

$\mu = 0.1$ for steel-steel in dry condition;

$\mu = 0$ for steel-steel in wet condition;

CS_i — safety working load of No. i lashing equipment, in kN, according to the breaking load of lashing equipment or yield stress of material, to be determined by the safety factor as shown in Table 4.1;

α — angle between No. i lashing equipment and the level, in°, as shown in Figure 4.1;

β — angle between No. i lashing equipment and vessel's longitudinal section, in°, as shown in Figure 4.1.

Safety factor K

Table 4.1

Ultimate load	Material of lashing equipment	K
Breaking load	Shackle, ring, deck hole, low-carbon steel turn buckle	3
	Fibre rope	4.5
	Wire rope, steel rib (disposable)	2
	Wire rope, steel rib (reusable)	5
	Steel chain	3
Yield stress	Welded steel structure (bent and compression) ⁽¹⁾	1.5
	Welded Steel structure (shearing)	2.6
	Butted full-penetration welds (tensile and compression)	1.5
	Butted full-penetration welds (shearing)	2.6
	Fillet welds (tensile and compression)	2.2
	Fillet welds (shearing)	2.6

Note (1) For the steel-bar-structure, when calculating the buckling strength, the criteria will be the permissible compression stress of the structure.

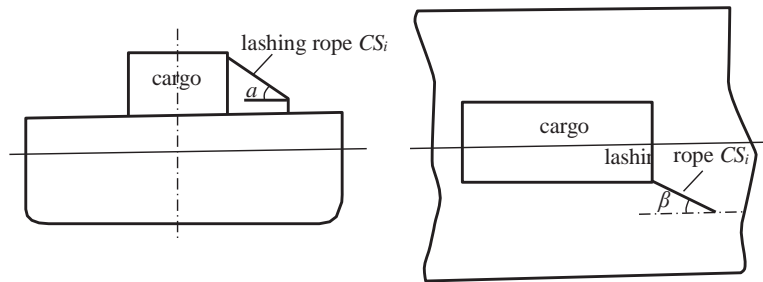

Figure 4.1

4.2 Transverse tipping

The balance of transverse tipping is to meet the following formula:

$$F_y \cdot a \leq b \cdot F_z(-) + \sum CS_i \cdot d_i$$

where: F_y , $F_z(-)$, CS_i — the same as in 4.1;

a, b, d_i — levers of force acting athwartships F_y , force acting perpendicular to the deck $F_z(-)$ and safety working load of No. i lashing equipment CS_i tipping around the centre of rotation respectively, in m, as shown in Figure 4.2.

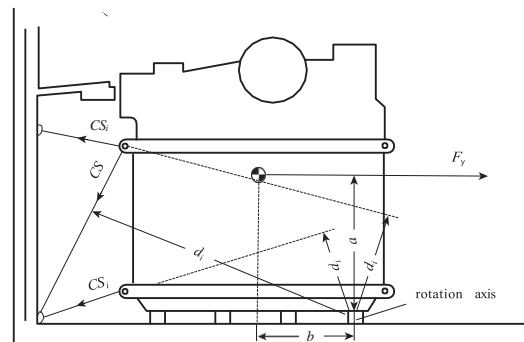

Figure 4.2

4.3 Longitudinal sliding

The balance of longitudinal sliding is to meet with the following formula:

$$F_x \leq \mu F_z(-) + \sum CS_i (\mu \cdot \sin \alpha + \cos \alpha \cdot \sin \beta)$$

where: F_x — forces acting in the longitudinal direction, in kN, to be calculated as in 2.2;
 μ , $F_z(-)$, CS_i , α , β — the same as in 4.1.

Appendix 2 Estimation of ocean towage resistance

1. The total ocean towage resistance R_T may be calculated by the following empirical equation:

$$R_T = 1.15 \left[R_f + R_B + (R_{fi} + R_{Bi}) \right] \quad \text{kN}$$

where: R_f — friction resistance of towed vessel, in kN;
 R_B — residual resistance of towed vessel, in kN;
 R_{fi} — friction resistance of towing vessel, in kN;
 R_{Bi} — residual resistance of towing vessel, in kN.

(1) The resistance of towed vessel or towed object may be determined by the following approximate formula:

$$R_f = 1.67 A_1 V^{1.83} \times 10^{-3} \quad \text{kN}$$

$$R_B = 0.147 \delta A_2 V^{1.74+0.15V} \quad \text{kN}$$

where: A_1 — wetted surface area under waterline of vessel or surface structure, in m^2 ;
 V — towage velocity, in m/s;
 δ — block coefficient;
 A_2 — submerged transverse section area amidships, in m^2 .

If there is no detailed data of wetted surface area A_1 , it may be obtained by the following:

$A_1 = L(1.7d + \delta B)$, in m^2 , for normal vessel;

$A_1 = 0.92L(B + 1.81d)$, in m^2 , for barge, box-shaped vessel with linear change in fore and aft;

$A_1 = L(B + 2d)$, in m^2 , for box-shaped vessel and other surface structure without any linear change.

where: L 、 B 、 d — respectively for length, breadth and towage draught of the vessel, in m;
 δ — block coefficient.

(2) Design data for towing vessel can be used for calculation of towage resistance R_{fi} and R_{Bi} , if no information there, the approximate formula in (1) above may be used for the calculation.

2. For drilling units or other surface structures with huge wind area, the towage resistance is also to be calculated as follows, taken whichever is the greater:

$$\sum R = 0.7(R_f + R_B) + R_a \quad \text{kN}$$

where: R_f 、 R_B — the same as is (1) above;

R_a — air resistance, calculated as follows:

$$R_a = 0.5 \rho V^2 \sum C_s A_i 10^{-3} \quad \text{kN}$$

where: ρ — air density, in kg/m³, to be taken as 1.22 kg/m³;
 V — wind velocity, in m/s, to be taken as 20.6 m/s;
 A_i — wind area, in m², to be taken as upwind;
 C_s — configuration coefficient of wind area A_i , to be taken as in table 3.2.1(2) of Chapter 3
of the Guidelines.

Appendix 3 Bollard pull testing procedure

- 1 A proposed test programme is to be submitted prior to the testing.
- 2 During testing of continuous bollard pull (BP) the main engine is to be run at the manufacturer's recommended maximum torque according to maximum continuous rating. Verification of the actual output is to be requested during the test.
- 3 During testing of overload pull, the main engine is to be run at the manufacturer's recommended maximum rating that can be maintained for minimum 30 min. The overload test may be omitted.
- 4 The propeller(s) fitted when performing the test is to be the propeller(s) used when the vessel is in normal operation.
- 5 All auxiliary equipment such as pumps, generators and other equipment which are driven from the main engine or propeller shafts in normal operation of the vessel are to be connected during the test.
- 6 The length of towline is not to be less than 300 m, measured between the stern of the vessel and the test bollard. However, the minimum length of towline is not to be less than twice the length of the vessel.
- 7 The water depth at the test location is not to be less than 20 m within a radius of 100 m of the vessel. If the water depth of 20 m can not be obtained at the test location, then a minimum water depth which is equal to twice the maximum draught of the vessel may be accepted. It is to be noted that reduced water depth may adversely affect the test results.
- 8 The test is to be carried out with the vessel's displacement corresponding to full ballast and half fuel capacity.
- 9 The vessel is to be trimmed at even keel or at a trim by stern not exceeding 2% of the vessel's length.
- 10 The vessel is to be able to maintain a fixed course for not less than 10 min while pulling as specified in items 2 or 3 above. Certified continuous bollard pull is the average reading of the 10 min period.
- 11 The test is to be performed with a wind velocity not exceeding 5 m/s.
- 12 The current at the test location is not to exceed 0.5 m/s in any direction.
- 13 The load cell used for the test is to be approved by a recognized competent organization and be accurate within $\pm 2\%$ within the range of loads to be measured and for the environmental conditions experienced during the test.
- 14 An instrument giving a continuous read-out and also a recording instrument recording the bollard pull graphically as a function of time is to be connected to the load cell. The instruments are if possible be placed and monitored ashore.

15 The load cell is to be fitted between the eye of the towline and the bollard.

16 The figure certified as the vessel's continuous bollard pull is to be the towing force recorded as being maintained without any tendency to decline for a duration of not less than 10 min.

17 Certification of bollard pull figures recorded when running the engine at overload, reduced RPM or with a reduced number of main engine or propeller operating can be given and noted on the certificate.

18 A communication system is to be established between the vessel and the person monitoring the load cell and the recording instrument ashore, by means of VHF or telephone connection, for the duration of the test.

Appendix 4 Towing log

Vessel _____ Date/Master sign _____

Main towline: (installed) Breaking load (M/T) _____ Length/Dia.: _____ Insp. Date/Year: _____

Spare towline: Breaking load (M/T) _____ Length/Dia.: _____ Insp. Date/Year: _____

Main towline: Lubricating(L) Maintenance (M) _____ Date: _____ Ref. Insp. Report, etc.: _____

Spare towline: Lubricating(L) Maintenance (M) _____ Date: _____ Ref. Insp. Report, etc.: _____

Towed Object: _____ Towline connected: Date/Hours: _____ Position: _____

Length of bridle/chain bridle (L): _____ Towline released: Date/Hours: _____ Position: _____

Towing information (Noon ~ Midnight or twice a day)							
From	To	Duration of wire rope used (total days/ hours)	Wire tension (M/T)	Wire length (m)	Environmental conditions	Wire length adjusted ± (m)	Remarks
Date/year	Hour	Date/year	Hour	Max.	Aver.	Wave (height/ direction/period)	Wind (force/ direction)
Total to be transferred to page				Remarks			

Appendix 5 Multiple towages

1 Definition

1.1 Double tow – two towed objects connected to the different towing equipment onboard the towing vessel individually via their towing equipment, see Figure 1.1.

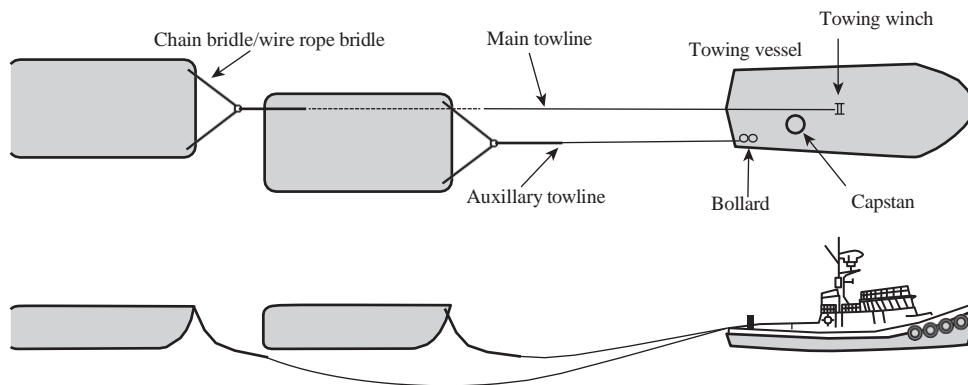

Figure 1.1 Diagram of double tow

1.2 Tandem tow – two or more towed objects are connected in series, i.e. the towing equipment of the behind towed object is connected to the bollard of the front one, then is connected with the towing equipment of towing vessel via the towing equipment onboard the front towed object, see Figure 1.2.

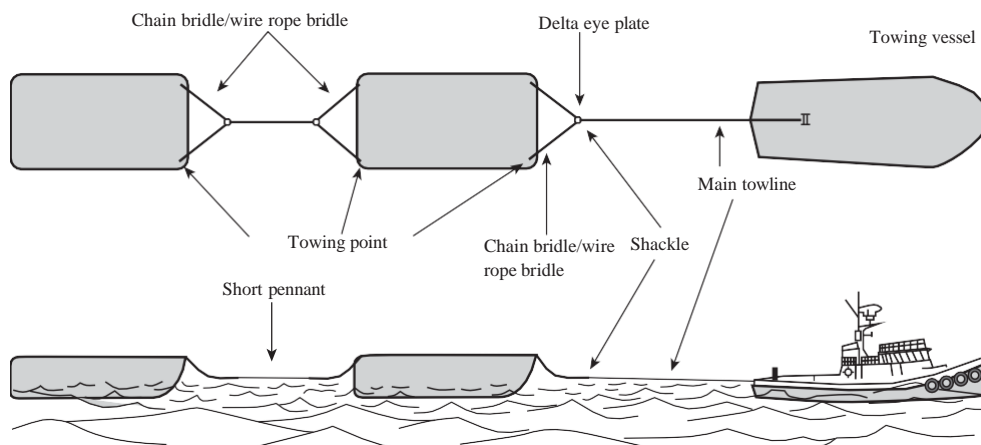

Figure 1.2 Diagram of tandem tow

1.3 Parallel tow – two or more towed objects are connected to the delta eye plates of main towline via their towing equipment (short pennants, shackles) individually, i.e. the main towline of the towing vessel is connected with the towed objects via several delta eye plates separately, see Figure 1.3.



Figure 1.3 Diagram of parallel tow

1.4 Multiple tugs to one tow – two or more towing vessels is used to tow a towed object, i.e. towline of the towing vessel is connected to the towing equipment (wire rope bridle, short pennant, etc.) onboard the towed object via delta eye plate, see Figure 1.4.

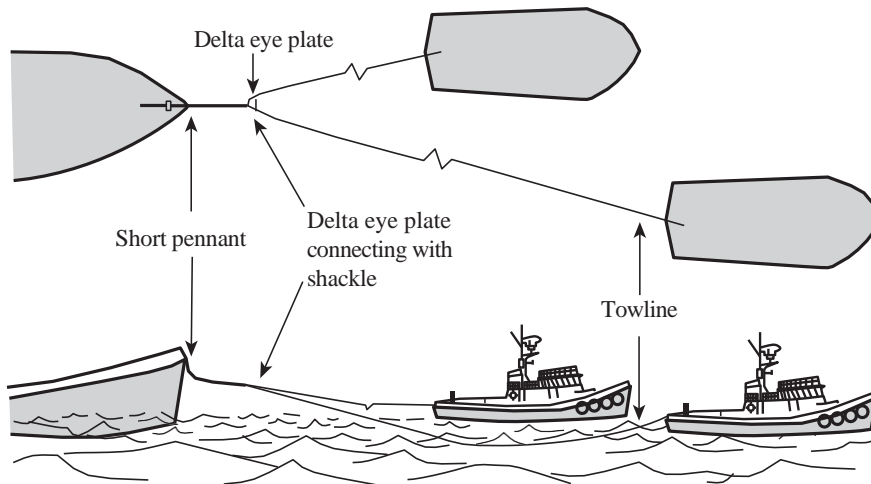

Figure 1.4 Diagram of multiple tugs to one tow

2 General requirements of multiple towages

2.1 The multiple towages have additional associated issues including those of:

- (1) maneuvering in close quarter situations;
- (2) reconnecting the main towlines after a breakage, generally during the period of towage;
- (3) maintaining sufficient water depth for towage operation due to the longer towline is required than the single towage.

2.2 The multiple towages may only be carried out in certain configurations, areas and seasons, and subject to a risk assessment.

2.3 All details of the operation for multiple towages, including the drawings, voyages and equipment specifications are to be submitted to ISC or a professional competent organization for evaluation.

2.4 If ISC or the professional competent organization has any doubts about the operation of multiple towage, the party concerned is to be required to take measures, otherwise, it will be rejected.

2.5 Each towed object carried out multiple towage is to meet the requirements of the Guidelines.

2.6 Safety factors are to be applied to the towing arrangements due to additional damage may be brought to the towing arrangements by the multiple towage, especially for towlines.

2.7 The bollard pull of towing vessel is to be determined by the number, configuration of the towed objects concerned and is at least the sum of those required of each towing vessel.

2.8 Where the towing configuration requires the use of two towlines from one towing vessel, a third towline is to be carried onboard the towing vessel and stowed in a protected position, whence it can be safely transferred at sea to either towing winch.

2.9 As required, other towing equipment such as chain, stretcher or catenary is to be considered to provide onboard.

3 Conditions of double tow

3.1 The conditions of double tow are as follows:

- (1) in benign areas;
- (2) for short duration towages covered by good weather forecasts;
- (3) where there is sufficient water depth along the tow route to allow for the catenary required;
- (4) the towing vessel is to be connected to each towed object with a separate towline on a separate winch drum.

4 Conditions of tandem tow

4.1 The conditions of tandem tow are as follows:

- (1) in very benign areas or in ice conditions where the towed objects will follow each other;
- (2) in ice conditions the towlines between towing vessel and lead towed object is to be short enough for the line to be clear of the water.

5 Conditions of parallel tow

5.1 In benign areas, the towing vessel has the greater bollard pull and safety factors are applied to the towing equipment.

6 Conditions of multiple tugs to one tow

6.1 This is generally considered acceptable, provided that each towing vessel has a separate towline to the towed vessel (via wire rope bridles or pennants as required). Care must be taken that the towing vessels do not foul each other or their towing equipment.

6.2 Consideration is to be given to matching the size and power of the towing vessels.

6.3 The use of eccentric bridles may be advantageous but care must be taken to avoid chafe.

6.4 Normally there will not be more than three towing vessels, except for the towage of very large objects, such as drilling units and offshore installations.